

# CE-1500EX

Keeping Australia clean

## Advanced Secondary Wastewater Treatment System

Hydraulic loading - 1500L / day (10ep)

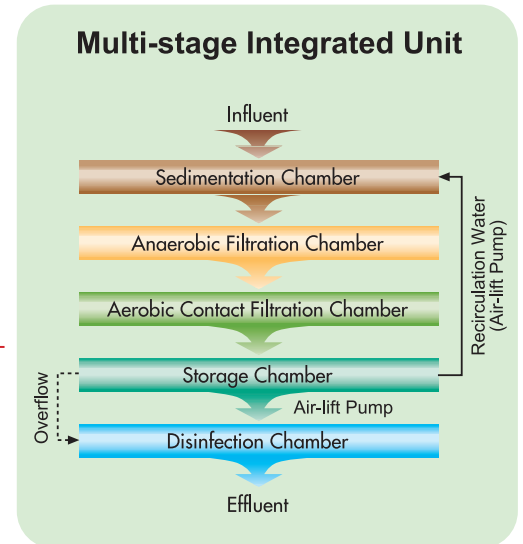
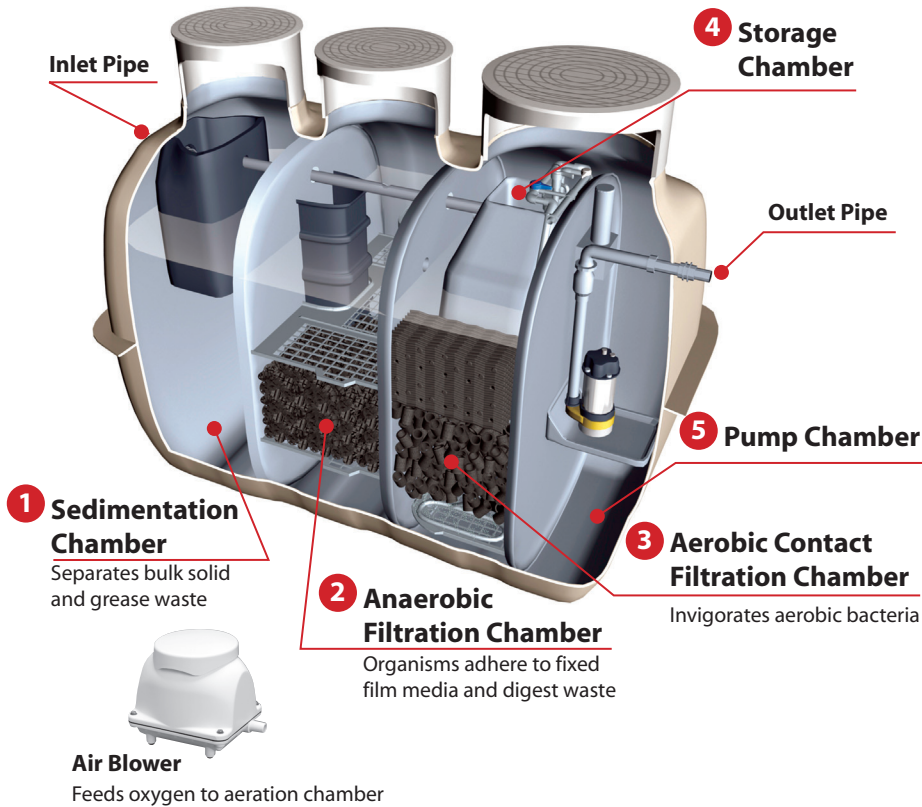

## FEATURES

### Reliable High Performance

Although the **CE-1500EX** is one of our standard models and is small and compact, its performance is extremely efficient and reliable

**CE-1500EX** has a Peak-cut System which can effectively cope with shock loadings. The water level in the system varies according to the presence of any inflow or not.

### Proven Design

With 45 years experience, Fuji Clean Co. Ltd. is the leading manufacturer of high efficiency wastewater systems in Japan, manufacturing and installing in excess of 40,000 units per annum.

### Easy Maintenance

The "Contact Filter bed process" is the unique treatment method developed by Fuji Clean.

The aeration pipes can be cleaned by inserting a brush under air or water flow. This makes for easy maintenance of the unit.

### Lower Operational Costs

The Air Blower used in the **CE-1500EX** is the most energy efficient in its class. It uses just 54 watts compared to 80 watts of other blowers. This results in much lower ongoing operational costs and makes the unit more environmentally friendly.

### Manufacturers Warranty

15 years for tank, 2 years for electrical components.

**MODEL CE-1500EX**

**Treatment Unit**

**Capacity (L)**

Sedimentation Chamber	1,114
Anaerobic Filtration Chamber	982
Aerobic Contact Filtration Chamber	580
Storage Chamber	281
Pump Out Chamber	1,402
Total Volume	4,667

**Dimensions (mm)**

Max. Width	1,440
Max length	2,510
Max Height	1,870
Inlet Invert	460
Inlet Pipe Nominal Size	dia. 100
Outlet Pipe Nominal Size	dia. 100

**Weight (kg)**

340

**Correspondent Blower Type**

MAC80N

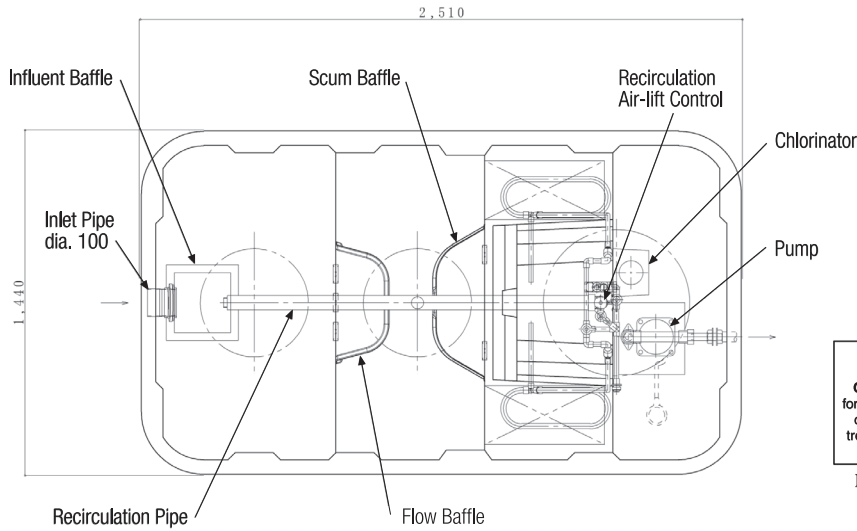

Horizontal Sectional View



Fuji Clean products are available in Australia through Fuji Clean Australia

Dimensions in mm

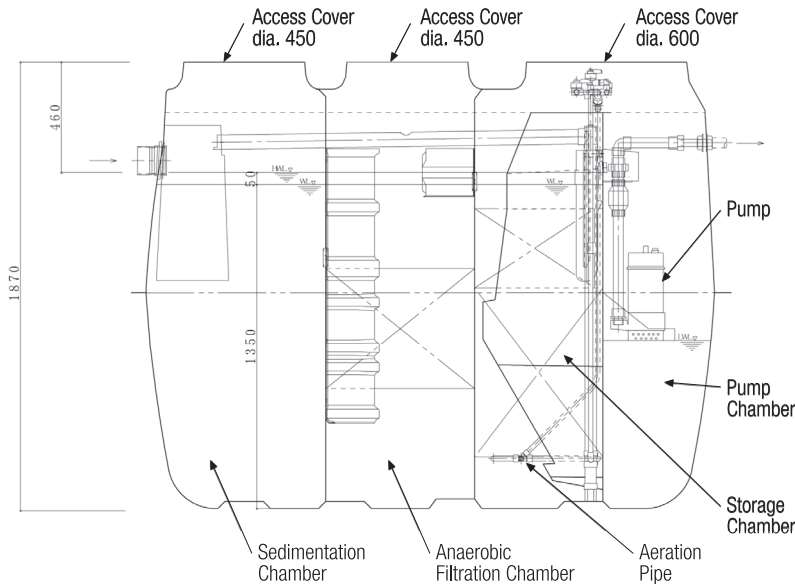

Vertical Sectional Views

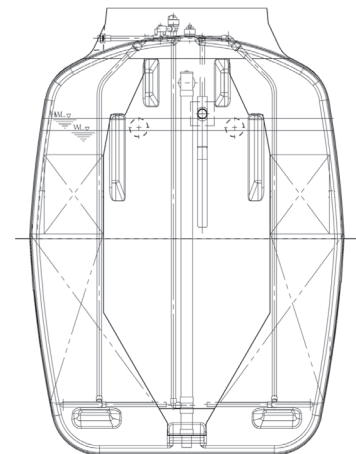

Your Agent:



**Make the Safe Choice**

Call 1300 668 225

or visit [www.watergurus.com.au](http://www.watergurus.com.au)

or email [info@watergurus.com.au](mailto:info@watergurus.com.au)